

# INTEGRATED ALGEBRA

The University of the State of New York  
REGENTS HIGH SCHOOL EXAMINATION

# INTEGRATED ALGEBRA

Thursday, August 13, 2009 — 8:30 to 11:30 a.m., only

Student Name: \_\_\_\_\_

School Name: \_\_\_\_\_

Print your name and the name of your school on the lines above. Then turn to the last page of this booklet, which is the answer sheet for Part I. Fold the last page along the perforations and, slowly and carefully, tear off the answer sheet. Then fill in the heading of your answer sheet.

This examination has four parts, with a total of 39 questions. You must answer all questions in this examination. Write your answers to the Part I multiple-choice questions on the separate answer sheet. Write your answers to the questions in Parts II, III, and IV directly in this booklet. All work should be written in pen, except graphs and drawings, which should be done in pencil. Clearly indicate the necessary steps, including appropriate formula substitutions, diagrams, graphs, charts, etc.

The formulas that you may need to answer some questions in this examination are found at the end of the examination. This sheet is perforated so you may remove it from this booklet.

Scrap paper is not permitted for any part of this examination, but you may use the blank spaces in this booklet as scrap paper. A perforated sheet of scrap graph paper is provided at the end of this booklet for any question for which graphing may be helpful but is not required. You may remove this sheet from this booklet. Any work done on this sheet of scrap graph paper will *not* be scored.

When you have completed the examination, you must sign the statement printed at the end of the answer sheet, indicating that you had no unlawful knowledge of the questions or answers prior to the examination and that you have neither given nor received assistance in answering any of the questions during the examination. Your answer sheet cannot be accepted if you fail to sign this declaration.

**Notice...**

A graphing calculator and a straightedge (ruler) must be available for you to use while taking this examination.

The use of any communications device is strictly prohibited when taking this examination. If you use any communications device, no matter how briefly, your examination will be invalidated and no score will be calculated for you.

**DO NOT OPEN THIS EXAMINATION BOOKLET UNTIL THE SIGNAL IS GIVEN.**

**Part I**

Answer all 30 questions in this part. Each correct answer will receive 2 credits. No partial credit will be allowed. For each question, write on the separate answer sheet the numeral preceding the word or expression that best completes the statement or answers the question. [60]

Use this space for computations.

1 If  $h$  represents a number, which equation is a correct translation of "Sixty more than 9 times a number is 375"?

(1)  $9h = 375$

(3)  $9h - 60 = 375$

(2)  $9h + 60 = 375$

(4)  $60h + 9 = 375$

2 Which expression is equivalent to  $9x^2 - 16$ ?

(1)  $(3x + 4)(3x - 4)$

(3)  $(3x + 8)(3x - 8)$

(2)  $(3x - 4)(3x - 4)$

(4)  $(3x - 8)(3x - 8)$

3 Which expression represents  $(3x^2y^4)(4xy^2)$  in simplest form?

(1)  $12x^2y^8$

(3)  $12x^3y^8$

(2)  $12x^2y^6$

(4)  $12x^3y^6$

4 An online music club has a one-time registration fee of \$13.95 and charges \$0.49 to buy each song. If Emma has \$50.00 to join the club and buy songs, what is the maximum number of songs she can buy?

(1) 73

(3) 130

(2) 74

(4) 131



Use this space for computations.

7 The spinner below is divided into eight equal regions and is spun once. What is the probability of *not* getting red?

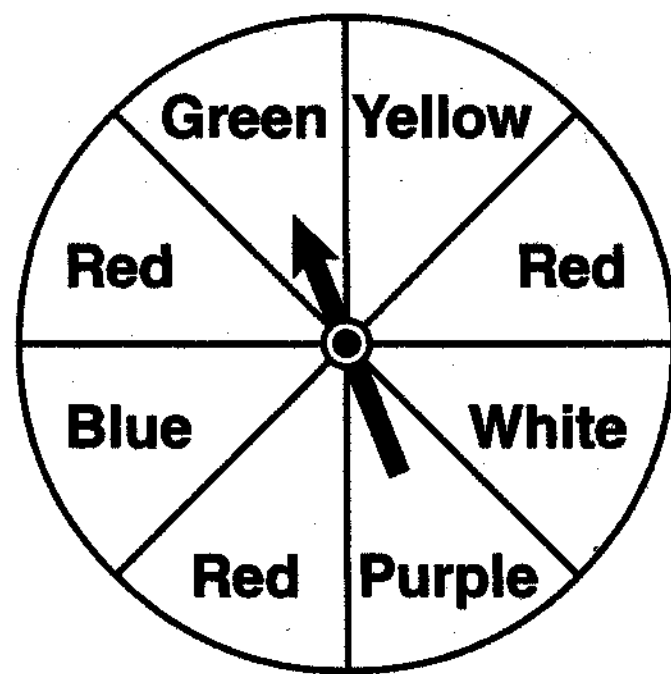

(1)  $\frac{3}{5}$

(3)  $\frac{5}{8}$

(2)  $\frac{3}{8}$

(4)  $\frac{7}{8}$

8 Which relationship can best be described as causal?

(1) height and intelligence

(2) shoe size and running speed

(3) number of correct answers on a test and test score

(4) number of students in a class and number of students with brown hair

9 Solve for  $x$ :  $\frac{3}{5}(x + 2) = x - 4$

(1) 8

(3) 15

(2) 13

(4) 23

Use this space for  
computations.

**10** Erica is conducting a survey about the proposed increase in the sports budget in the Hometown School District. Which survey method would likely contain the *most* bias?

- (1) Erica asks every third person entering the Hometown Grocery Store.
- (2) Erica asks every third person leaving the Hometown Shopping Mall this weekend.
- (3) Erica asks every fifth student entering Hometown High School on Monday morning.
- (4) Erica asks every fifth person leaving Saturday's Hometown High School football game.

**11** Which equation represents a line parallel to the  $x$ -axis?

- |               |              |
|---------------|--------------|
| (1) $y = -5$  | (3) $x = 3$  |
| (2) $y = -5x$ | (4) $x = 3y$ |

**12** Given:

$A = \{\text{All even integers from 2 to 20, inclusive}\}$

$B = \{10, 12, 14, 16, 18\}$

What is the complement of set  $B$  within the universe of set  $A$ ?

- |                      |                          |
|----------------------|--------------------------|
| (1) $\{4, 6, 8\}$    | (3) $\{4, 6, 8, 20\}$    |
| (2) $\{2, 4, 6, 8\}$ | (4) $\{2, 4, 6, 8, 20\}$ |

**13** Which value of  $x$  is in the solution set of the inequality  $-2(x - 5) < 4$ ?

- |       |       |
|-------|-------|
| (1) 0 | (3) 3 |
| (2) 2 | (4) 5 |



16 The equation  $y = -x^2 - 2x + 8$  is graphed on the set of axes below.

Use this space for  
computations.

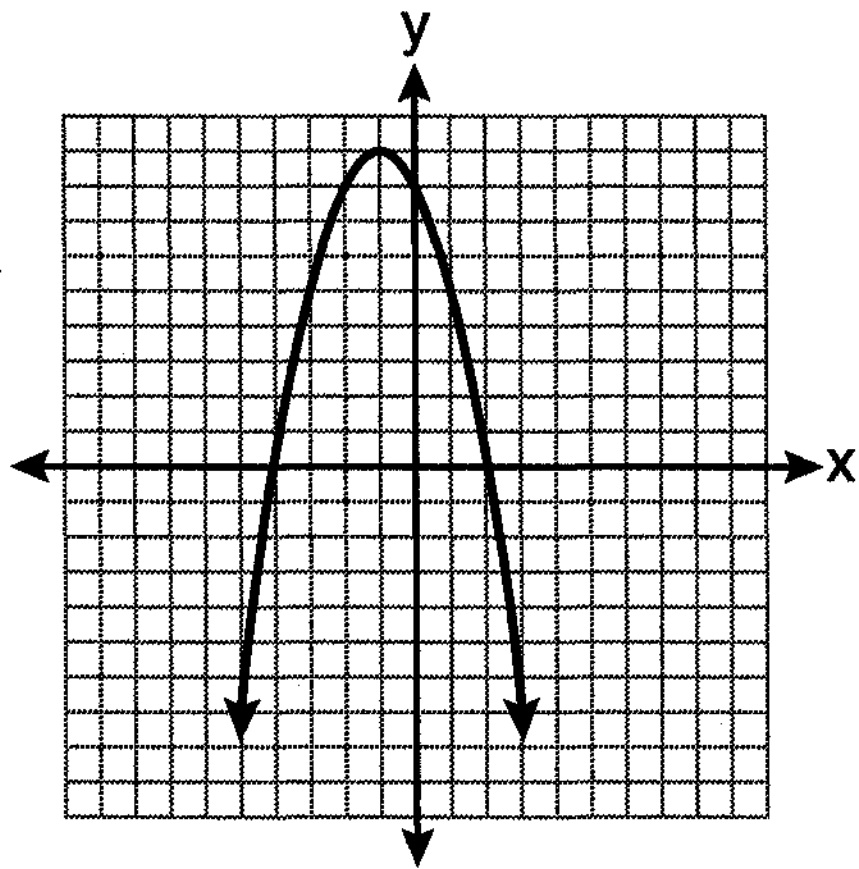

Based on this graph, what are the roots of the equation  $-x^2 - 2x + 8 = 0$ ?

- (1) 8 and 0                      (3) 9 and -1  
(2) 2 and -4                    (4) 4 and -2

17 What is the sum of  $\frac{3}{2x}$  and  $\frac{4}{3x}$  expressed in simplest form?

- (1)  $\frac{12}{6x^2}$                       (3)  $\frac{7}{5x}$   
(2)  $\frac{17}{6x}$                         (4)  $\frac{17}{12x}$



Use this space for  
computations.

22 When  $5\sqrt{20}$  is written in simplest radical form, the result is  $k\sqrt{5}$ .  
What is the value of  $k$ ?

- (1) 20                                      (3) 7  
(2) 10                                      (4) 4

23 What is the value of the expression  $|-5x + 12|$  when  $x = 5$ ?

- (1) -37                                      (3) 13  
(2) -13                                      (4) 37

24 A playground in a local community consists of a rectangle and two semicircles, as shown in the diagram below.

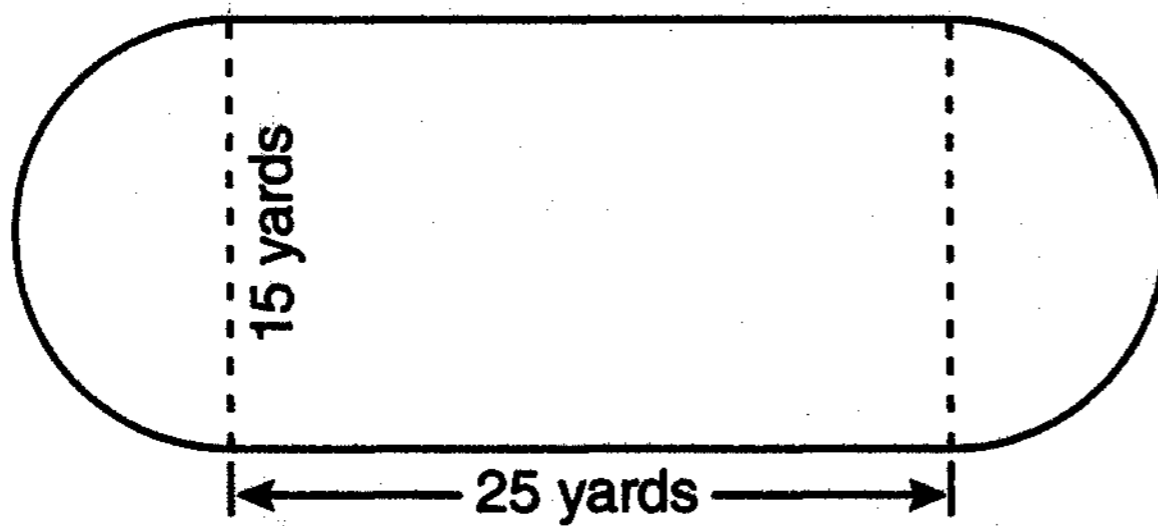

Which expression represents the amount of fencing, in yards, that would be needed to completely enclose the playground?

- (1)  $15\pi + 50$                               (3)  $30\pi + 50$   
(2)  $15\pi + 80$                               (4)  $30\pi + 80$

25 Which equation is represented by the graph below?

Use this space for  
computations.

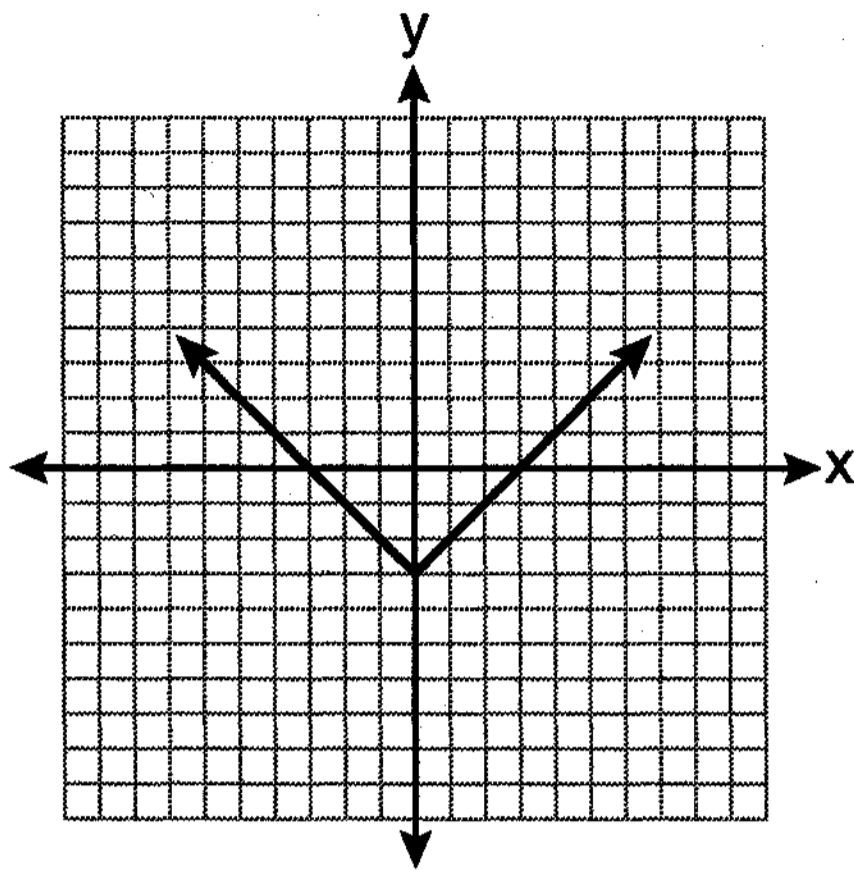

(1)  $y = x^2 - 3$

(3)  $y = |x| - 3$

(2)  $y = (x - 3)^2$

(4)  $y = |x - 3|$

26 Carrie bought new carpet for her living room. She calculated the area of the living room to be 174.2 square feet. The actual area was 149.6 square feet. What is the relative error of the area to the nearest ten-thousandth?

(1) 0.1412

(3) 1.8588

(2) 0.1644

(4) 2.1644

27 What is an equation of the line that passes through the point (3,-1) and has a slope of 2?

(1)  $y = 2x + 5$

(3)  $y = 2x - 4$

(2)  $y = 2x - 1$

(4)  $y = 2x - 7$



## Part II

Answer all 3 questions in this part. Each correct answer will receive 2 credits. Clearly indicate the necessary steps, including appropriate formula substitutions, diagrams, graphs, charts, etc. For all questions in this part, a correct numerical answer with no work shown will receive only 1 credit. [6]

31 Chad complained to his friend that he had five equations to solve for homework. Are all of the homework problems equations? Justify your answer.

### Math Homework

1.  $3x^2 \cdot 2x^4$

2.  $5 - 2x = 3x$

3.  $3(2x + 7)$

4.  $7x^2 + 2x - 3x^2 - 9$

5.  $\frac{2}{3} = \frac{x+2}{6}$

Name Chad

32 The diagram below represents Joe's two fish tanks.

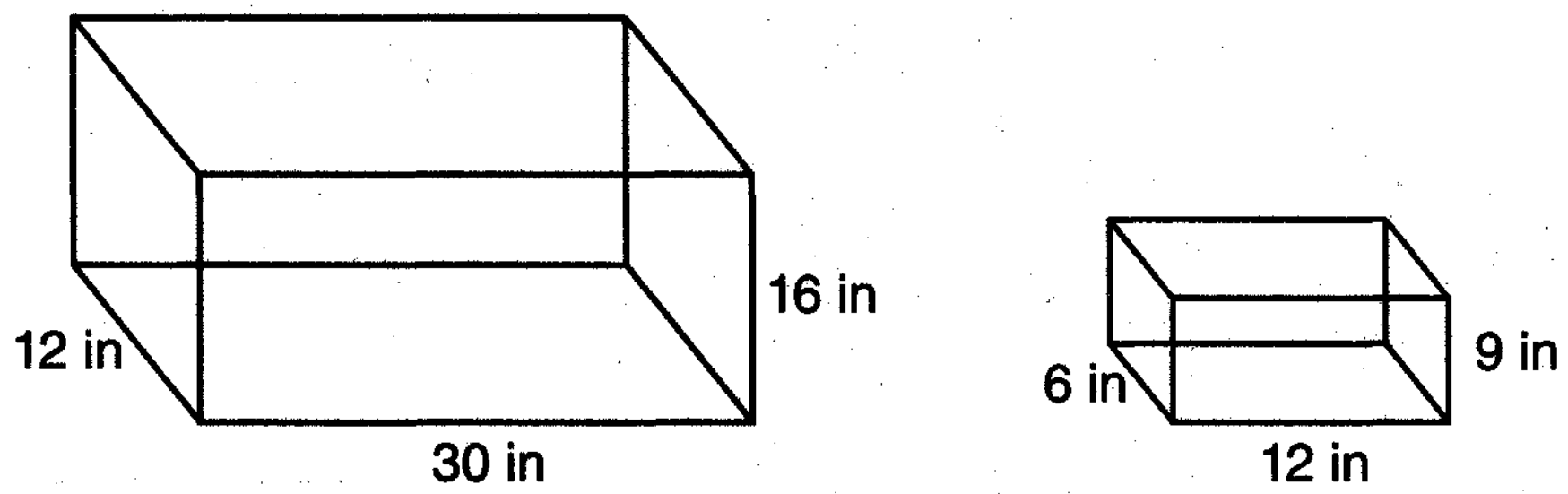

Joe's larger tank is completely filled with water. He takes water from it to completely fill the small tank. Determine how many cubic inches of water will remain in the larger tank.

**33** Clayton has three fair coins. Find the probability that he gets two tails and one head when he flips the three coins.

### Part III

Answer all 3 questions in this part. Each correct answer will receive 3 credits. Clearly indicate the necessary steps, including appropriate formula substitutions, diagrams, graphs, charts, etc. For all questions in this part, a correct numerical answer with no work shown will receive only 1 credit. [9]

34 Find algebraically the equation of the axis of symmetry and the coordinates of the vertex of the parabola whose equation is  $y = -2x^2 - 8x + 3$ .

**35** At the end of week one, a stock had increased in value from \$5.75 a share to \$7.50 a share. Find the percent of increase at the end of week one to the *nearest tenth of a percent*.

At the end of week two, the same stock had decreased in value from \$7.50 to \$5.75. Is the percent of decrease at the end of week two the same as the percent of increase at the end of week one? Justify your answer.

**36** The chart below compares two runners.

<b>Runner</b>	<b>Distance, in miles</b>	<b>Time, in hours</b>
Greg	11	2
Dave	16	3

Based on the information in this chart, state which runner has the faster rate. Justify your answer.

**Part IV**

**Answer all 3 questions in this part. Each correct answer will receive 4 credits. Clearly indicate the necessary steps, including appropriate formula substitutions, diagrams, graphs, charts, etc. For all questions in this part, a correct numerical answer with no work shown will receive only 1 credit. [12]**

**37** Express in simplest form:  $\frac{2x^2 - 8x - 42}{6x^2} \div \frac{x^2 - 9}{x^2 - 3x}$

38 On the grid below, solve the system of equations graphically for  $x$  and  $y$ .

$$4x - 2y = 10$$

$$y = -2x - 1$$

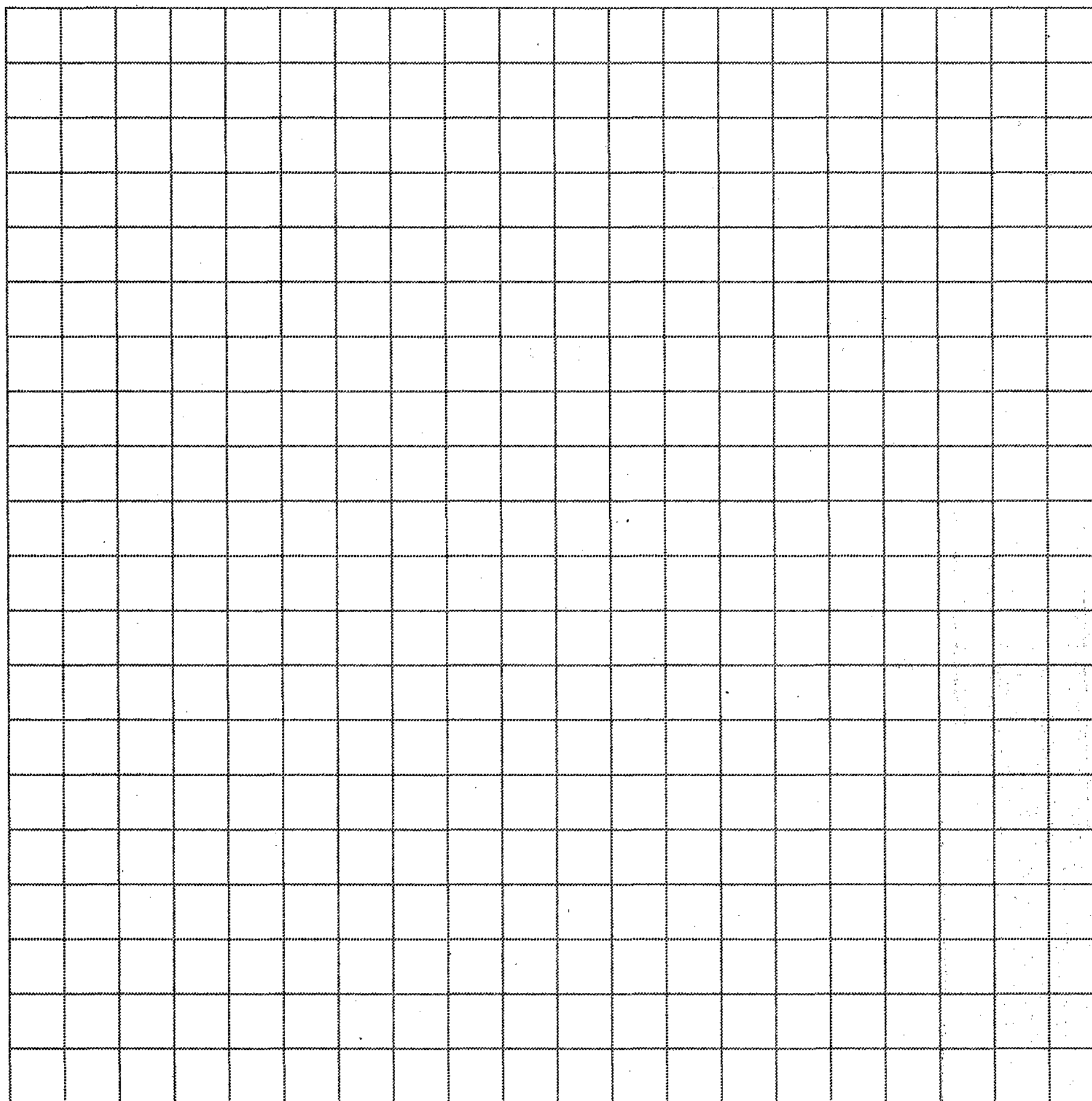

39 The test scores from Mrs. Gray's math class are shown below.

72, 73, 66, 71, 82, 85, 95, 85, 86, 89, 91, 92

Construct a box-and-whisker plot to display these data.

